

MICROMINIATURE POLARIZED LATCHING RELAY

FEATURES

- Single and dual coil latching versions
- High dielectric and surge voltage:
2.5 kV surge (per Bellcore TA-NWT-001089)
1.5 kV surge (per FCC Part 68)
1,000 Vrms, open contacts
- Low power consumption: 79 mW pickup
- Stable contact resistance for low level signal switching
- Epoxy sealed
- UL, CUR file E43203
- All plastics meet UL94 V-O, 30 min. oxygen index



CONTACTS

Arrangement	DPDT (2 Form C) Bifurcated crossbar contacts
Ratings	Resistive load: Max. switched power: 60 W or 62.5 VA Max. switched current: 2.0 A Max. switched voltage: 220 VDC or 250 VAC
Rated Load UL/CSA	0.25 A at 240 VAC 0.5 A at 125 VAC 2.0 A at 30 VDC 0.3 A at 110 VDC
Material	Silver nickel gold plated Silver palladium available upon request

GENERAL DATA

Life Expectancy Mechanical Electrical	Minimum operations 1 x 10 ⁸ 1 x 10 ⁵ at 0.5 A, 125 VAC, resistive 2 x 10 ⁵ at 1.0 A, 30 VDC, resistive
Operate Time (set) (typical)	3 ms at nominal coil voltage
Release Time (reset) (typical)	3 ms at nominal coil voltage (with no coil suppression)
Bounce (typical)	At 10 mA contact current 1 ms at operate or release
Dielectric Strength (at sea level)	See table
Insulation Resistance	10 ⁹ ohms min. at 25°C, 500 VDC, 50% RH
Ambient Temperature Operating Storage	At nominal coil voltage -40°C (-40°F) to 85°C (185°F) -40°C (-40°F) to 105°C (221°F)
Vibration	Operational, 35 g, 10–1000 Hz
Shock	Operational, 50 g min., 11 ms Non-destructive, 150 g min., 11 ms
Max. Solder Temp. Temp./Time	See soldering profile
Max. Solvent Temp.	80°C (176°F)
Max. Immersion Time	30 seconds
Weight	2.5 grams
Enclosure	P.B.T. polyester
Terminals	Tinned copper alloy, P.C.
Packing unit in pcs THT SMT long terminals SMT short terminals	50 per plastic tube / 2000 per carton box 400 per reel / 2000 per carton box 500 per reel / 2500 per carton box

COIL (Polarized)

Power At Pickup Voltage (typical)	79 mW (dual coil) 39 mW (single coil)
Max. Continuous Dissipation	1.0 W at 20°C (68°F)
Temperature Rise	At nominal coil voltage 18°C (32°F)
Temperature	Max. 110°C (230°F)

NOTES

1. All values at 20°C (68°F).
2. Relay may pull in with less than "Must Operate" value.
3. Relay has fixed coil polarity.
4. Specifications subject to change without notice.

Discontinuation Notice

Discontinuation date:

Date of last order:

Recommended replacement:

31.12.2012

30.06.2012

AZ8462

AZ833P

RELAY ORDERING DATA

COIL SPECIFICATIONS				Order Number		
STANDARD RELAYS: Bistable, 2 coils				THT Through Hole	SMT Long	SMT Short
Nominal Coil VDC	Set / Reset VDC	Max. Continuous VDC	Coil Resistance Ohm $\pm 10\%$			
3	2.25	6.5	64.3	AZ833P2-3DE	AZ833P2S1-3DE	AZ833P2S2-3DE
4.5	3.38	9.8	145	AZ833P2-4.5DE	AZ833P2S1-4.5DE	AZ833P2S2-4.5DE
5	3.75	10.9	178	AZ833P2-5DE	AZ833P2S1-5DE	AZ833P2S2-5DE
6	4.50	13.0	257	AZ833P2-6DE	AZ833P2S1-6DE	AZ833P2S2-6DE
9	6.75	19.6	578	AZ833P2-9DE	AZ833P2S1-9DE	AZ833P2S2-9DE
12	9.00	26.2	1,029	AZ833P2-12DE	AZ833P2S1-12DE	AZ833P2S2-12DE
24	18.00	52.3	4,114	AZ833P2-24DE	AZ833P2S1-24DE	AZ833P2S2-24DE

STANDARD RELAYS: Bistable, 1 coil				Order Number		
Nominal Coil VDC	Set / Reset VDC	Max. Continuous VDC	Coil Resistance Ohm $\pm 10\%$	THT Through Hole	SMT Long	SMT Short
3	2.25	9.2	128	AZ833P1-3DE	AZ833P1S1-3DE	AZ833P1S2-3DE
4.5	3.38	13.8	289	AZ833P1-4.5DE	AZ833P1S1-4.5DE	AZ833P1S2-4.5DE
5	3.75	15.3	357	AZ833P1-5DE	AZ833P1S1-5DE	AZ833P1S2-5DE
6	4.50	18.5	514	AZ833P1-6DE	AZ833P1S1-6DE	AZ833P1S2-6DE
9	6.75	27.7	1,157	AZ833P1-9DE	AZ833P1S1-9DE	AZ833P1S2-9DE
12	9.00	37.0	2,057	AZ833P1-12DE	AZ833P1S1-12DE	AZ833P1S2-12DE
24	18.00	74.0	8,228	AZ833P1-24DE	AZ833P1S1-24DE	AZ833P1S2-24DE

INITIAL DIELECTRIC STRENGTH (minimum)

	V_{rms} 1 min.	Surge peak (V) according to IEC 60950 (10/700 μs) and Telecordia TR-NWT-001089 (2/10 μs)
Between open contacts	1,000	2,500
Between contact set	1,000	2,500
Between coil and contacts	1,500	2,500*

* For 1 coil version only

LOAD LIMIT CURVE

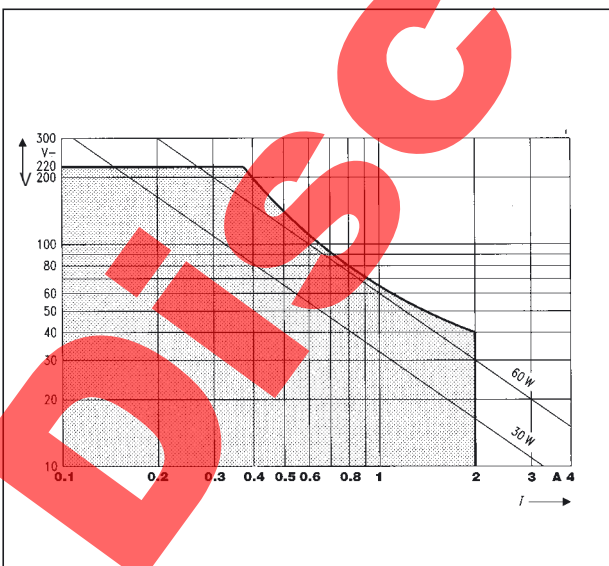

RECOMMENDED SOLDERING PROFILE

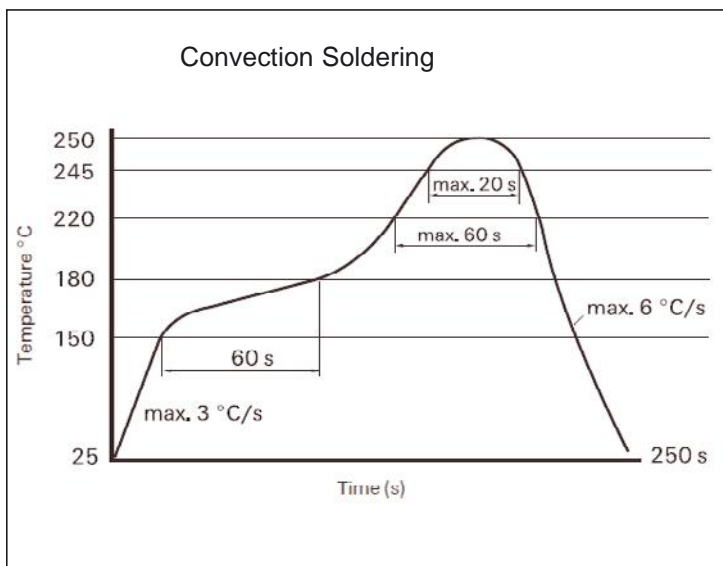

ZETTLER electronics GmbH

Junkersstrasse 3, D-82178 Puchheim, Germany

Tel. +49 89 800 97 0
Fax +49 89 800 97 200

office@ZETTLERelectronics.com
www.ZETTLERelectronics.com

AZ833P

Discontinuation Notice

Discontinuation date:

31.12.2012

Date of last order:

30.06.2012

Recommended replacement:

AZ8462

MECHANICAL DATA

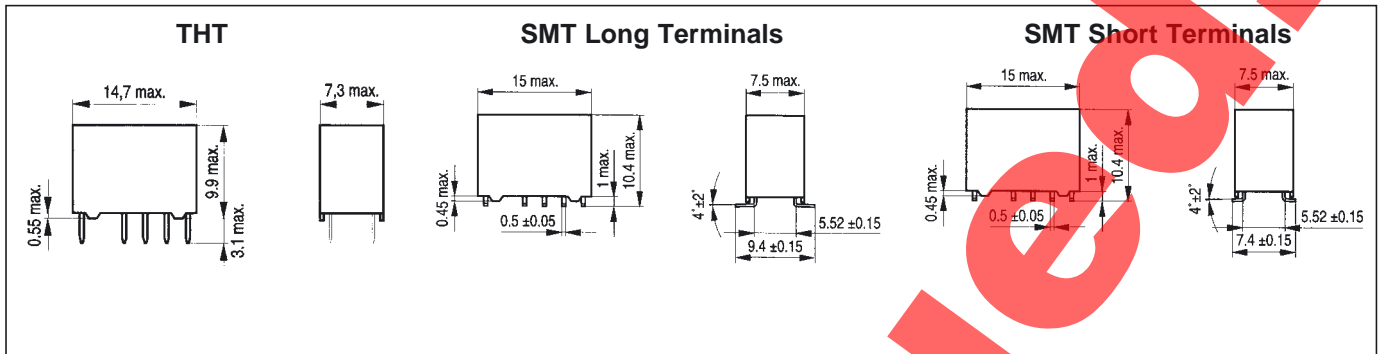

PCB Layout

Viewed toward terminals

Orientation mark

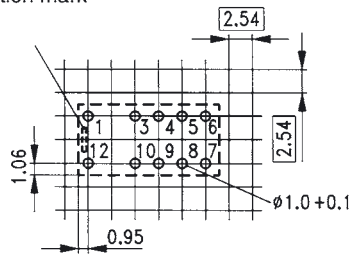

Note: Hole for pin 6 and 7 only for bistable with 2 windings

Solder Pad Layout

Viewed toward the component side of the PCB

Long terminals

Short terminals

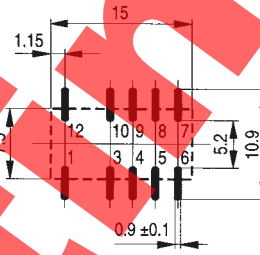

Note: Solder pad for pin 6 and 7 only for bistable with 2 windings

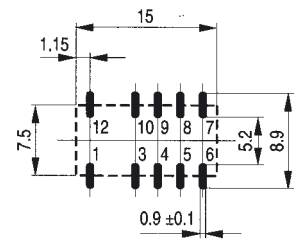

Wiring Diagram

bistable, 1 winding

Viewed toward terminals

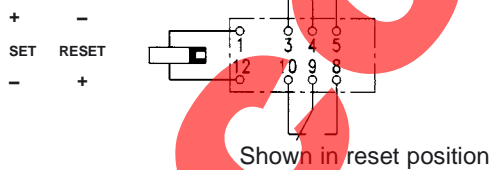

bistable, 1 winding

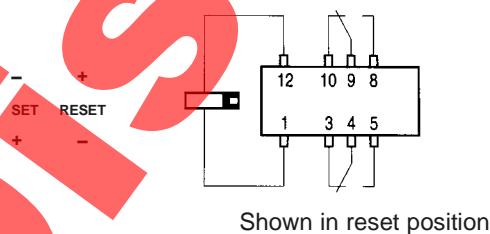

Bistable, 2 windings

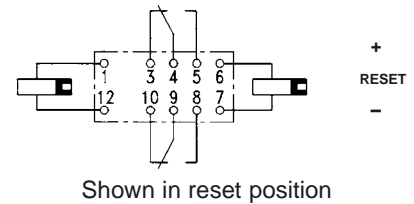

Bistable, 2 windings

Viewed toward component side of PCB

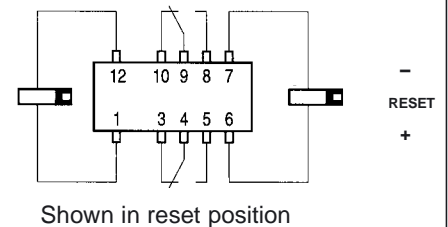

All dimensions in mm

ZETTLER electronics GmbH

Junkersstrasse 3, D-82178 Puchheim, Germany

Tel. +49 89 800 97 0
Fax +49 89 800 97 200

office@ZETTLERelectronics.com
www.ZETTLERelectronics.com

2010-07-07

PACKAGING

Tape and reel for SMT version with long terminals – AZ833P1S1 or AZ833P2S1

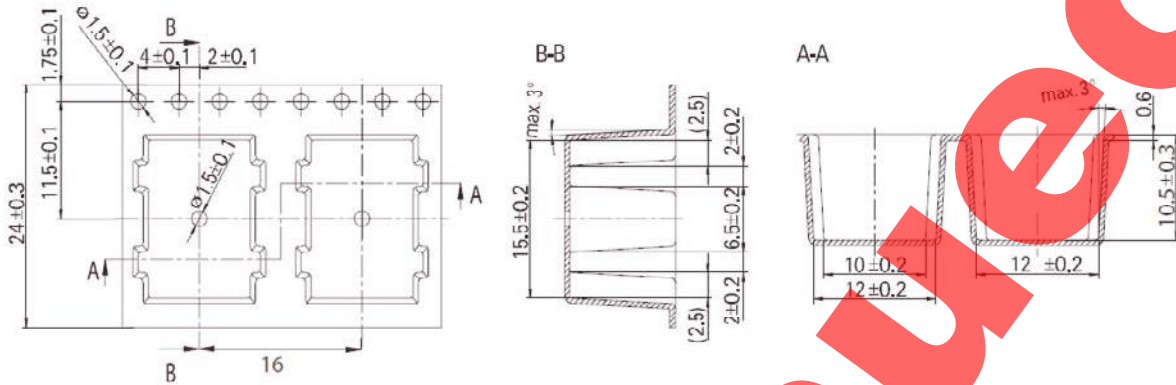

Tape and reel for SMT version with short terminals – AZ833P1S2 or AZ833P2S2

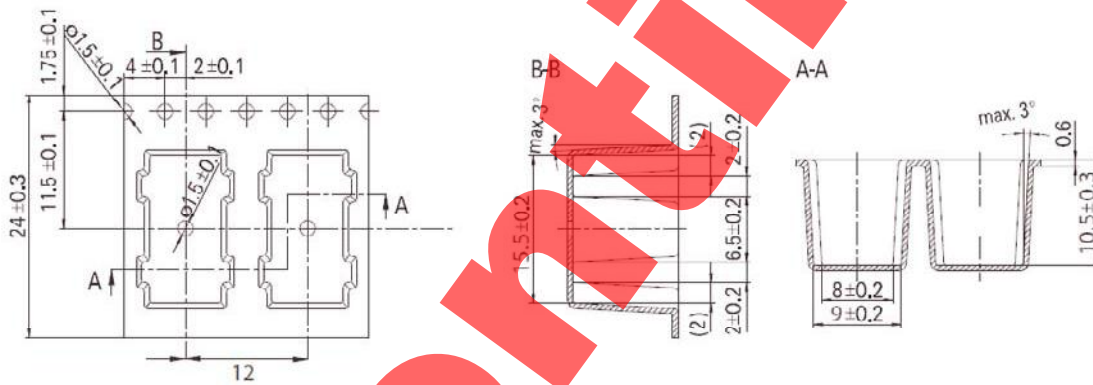

Tube for THT version – AZ833P1 or AZ833P2

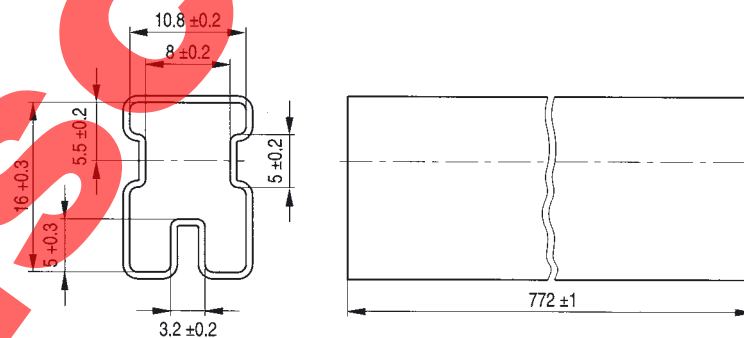

All dimensions in mm