

10 AMP SUBMINIATURE POWER RELAY

FEATURES

- 10 Amp switching capability
- 4 kV dielectric strength, Isolation spacing ≥ 8 mm
- Reinforced insulation according IEC 60730-1 and IEC 60335-1
- Versions with gold plated contact available
- Epoxy sealed versions available
- Highly sensitive coils with only 110 mW pickup power
- VDE and UL/CUR approved

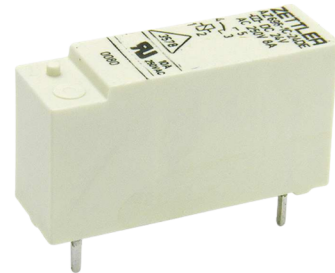

CONTACTS

Arrangement	SPST-NO (1 Form A) SPST-NC (1 Form B) SPDT (1 Form C)
Ratings (max.) switched power switched current switched voltage	(resistive load) 300 W or 2500 VA 10 A 240 VDC* or 440 VAC * Note: If switching voltage is greater than 30 VDC, special precautions must be taken. Please contact the factory.
Rated Loads UL, CUR	10 A at 30 VDC, resistive, 70°C 10 A at 250 VAC, general use, 70°C ¼ HP at 120 VAC, 70°C ½ HP at 250 VAC, 70°C B300 pilot duty
VDE	flux proof versions 10 A at 250 VAC, resistive, 50k cycles, 85°C wash tight versions 10 A at 250 VAC, resistive, 10k cycles, 85°C Note: 9 VDC coil version is not VDE approved
Contact material	AgSnO ₂ / AgSnO ₂ +Au (silver tin oxide / Au plating)
Initial resistance	< 30 mΩ (1A / 6VDC, voltage drop method)

COIL

Nominal coil voltages	see coil voltage specifications table
Dropout DC coil types	> 10% of nominal coil voltage
Coil power nominal at pickup voltage	typ. at 23°C (73°F) ambient temperature see coil voltage specifications table 110 mW (48 VDC coil: 140 mW)
Temperature Rise	20 K (36°F) at nominal coil voltage
Max. temperature	155°C (311°F), class F

GENERAL DATA

Life Expectancy mechanical electrical	(minimum operations) 1 x 10 ⁷ 1 x 10 ⁵ at 8 A 250 VAC resistive load
Operate Time typ.	(at nominal coil voltage) 10 ms
Release Time typ.	(at nom. coil voltage, without coil suppression) 5 ms
Dielectric Strength coil to contacts between open contacts	(at sea level for 1 min.) 4000 VAC 1000 VAC
Insulation Resistance	1000 MΩ (min.) at 23°C, 500 VDC, 50% RH
Isolation spacing clearance / creepage	(coil to contact) ≥ 8 mm / ≥ 8 mm
Insulation coil to contacts	Reinforced insulation (rated voltage: 250 VAC, pollution degree: 3, overvoltage category: III)
Temperature Range operating	(at nominal coil voltage) -40°C (-40°F) to 85°C (185°F)
Vibration resistance	1.5 mm DA at 10–55 Hz
Shock resistance	20g
Enclosure protection category material group flammability	PBT polyester flux proof, wash tight IIIa UL94 V-0
Terminals	Tinned copper alloy, THT PCB mounting
Soldering preheating soldering	(referring IEC 61760-1 wave soldering) 120°C (248°F) / ≤ 120 s 260 \pm 5°C (500 \pm 9°F) / $\leq 2 \times 5$ s
Cleaning max. solvent temp. max. immersion time	(RT III - wash tight versions only) 80°C (176°F) 30 seconds
Dimensions 1 Form A / 1 Form B 1 Form C	(L/W/H) 28 mm / 10 mm / 16.2 mm 30 mm / 10 mm / 16.2 mm
Weight	11 grams (approx.)
Compliance	IEC 61810-1, UL 508, RoHS, REACH
Agency Approvals VDE UL / CUR	40012571 E43203
Packing unit in pcs 1 Form A / 1 Form B 1 Form C	20 per carton tube / 1200 per carton box 19 per carton tube / 1140 per carton box

AZ696

COIL VOLTAGE SPECIFICATIONS

Nominal Coil VDC	Must Operate VDC	Max. Coil VDC	Coil Power mW (ref.)	Resistance Ohm $\pm 10\%$
5	3.5	12.0	227	110
6	4.2	14.5	225	160
9 *	6.3	22.0	225	360
12	8.4	29.5	218	660
18	12.6	44.0	216	1500
24	16.8	54.0	262	2200
48	33.6	102.0	288	8000

Notes: 1. All values at 23°C, upright position, terminals downward.
 2. Max. coil VDC is the voltage the coil can endure for a short period of time.
 3. Values for coil power for reference only.
 * 9 VDC coil version is not VDE approved.

ORDERING DATA

AZ696-□□E-□□D□□

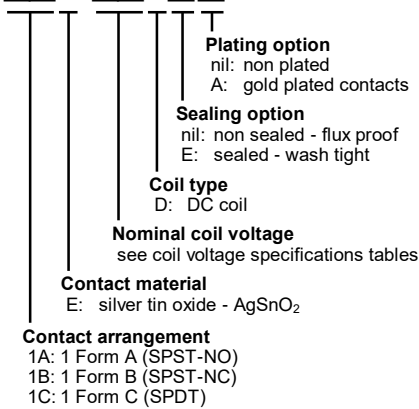

Example ordering data

AZ696-1AE-12D 1 Form A (SPST-NO), 12 VDC nominal coil voltage, flux proof version

AZ696-1CE-24DE 1 Form C (SPDT), 24 VDC nominal coil voltage, wash tight version

WIRING DIAGRAMS

Viewed towards terminals.

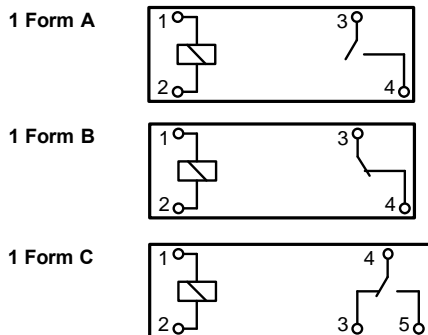

DC COIL OPERATING RANGE

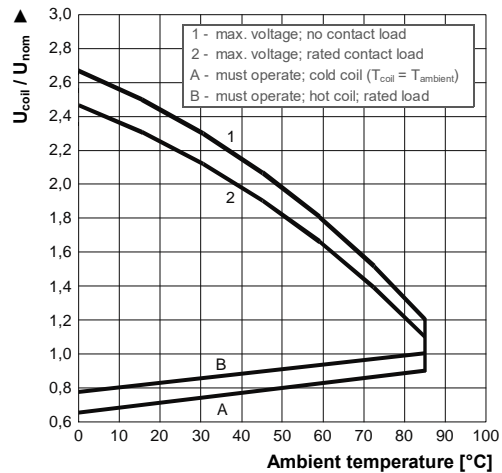

SWITCHING CAPACITY

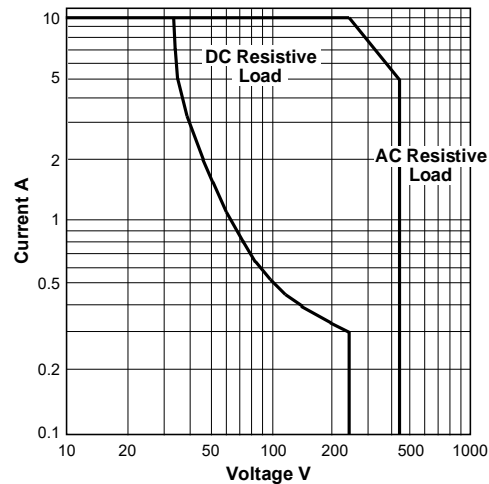

INDUCTIVE LOADS LIFE REDUCTION

Electrical life reduction factor at inductive AC load

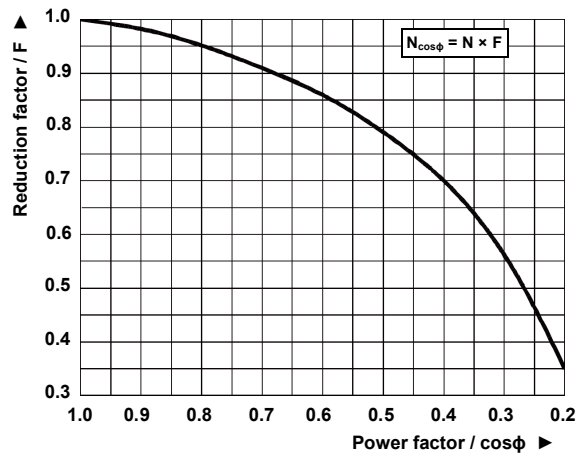

AZ696

MECHANICAL DATA

Dimensions in mm. Outline tolerance ± 0.3 mm.
Note: * Pin dimensions for reference only and given without tin coating.

1 Form A / 1 Form B

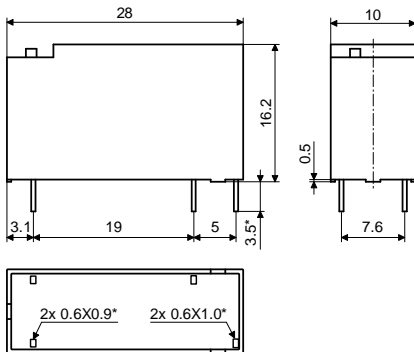

1 Form C

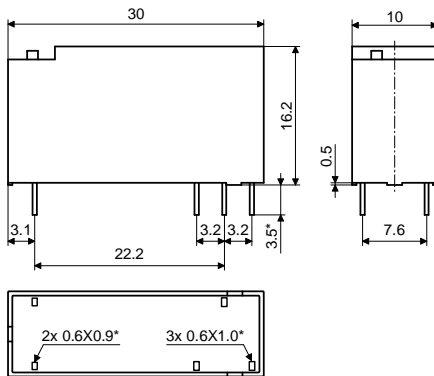

PCB FOOTPRINT

Layout and footprint recommendation. Dimensions in mm.
Viewed towards terminals.

1 Form A / 1 Form B

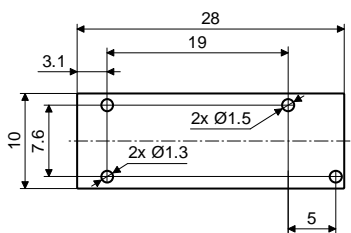

1 Form C

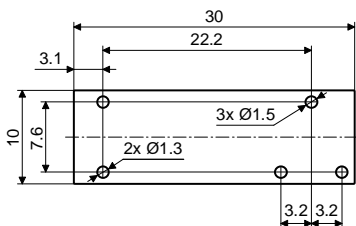

NOTES

- All values in this datasheet are at reference temperature of 23°C (73°F) unless stated otherwise.
- The relay may pull in and operate with less than the specified *must operate* voltage value.
- The coil's *must operate* voltage and the coil's *resistance* value depend on the temperature of the coil. The specified values are given for a coil temperature of 23°C and increase by approx. 0.39% per Kelvin of temperature rise.
- Coil suppression circuits such as diodes, etc. in parallel to the coil will lengthen the release time.
- Relays are electromechanical components that are sensitive to shock. The relay's adjustment can be affected if the relay is subjected to excessive shock or excessive pressure is applied to the relay case. Relays which have been dropped must no longer be used.
- Substances containing silicone or phosphorus must be avoided in the vicinity to the relay. Outgassing from these substances can penetrate the relay and adhere on the contacts. Deposits of these substances may act as insulators and adversely affect the contact resistance. Silicone can be found e.g. in gaskets, lubricants or filling materials, phosphorus can be found e.g. as a flame retardant in plastics.
- Prevent non-sealed relays from atmospheres subject to dust. Dust particles may enter the case and get stuck between the contacts, causing the contact circuits to fail.
- Do not use these relays in environments with explosive or flammable gases. Electrical arcing at the contacts could ignite these gases and cause fire.
- Avoid high frequency or ultrasonic vibrations on the relays as these can cause contact welding and misalignment or destruction of internal structures.
- During operation, storage and transport, ambient temperature should be within the specified operating temperature range. Humidity should be in the range of 5% to 85% RH. Icing and condensation must be avoided. Relays stored for an extended period of time may show initially increased contact resistance values due to chemical effects such as oxidation.
- For automated dual wave soldering process we recommend preheating with 120°C (248°F) for max. 120 seconds and a soldering temperature of 260 ± 5 °C (500 ± 9 °F) for max. 10 seconds soldering time (max. 5 seconds per wave). For manual soldering we recommend 350°C (662°F) max. temperature for max. 5 seconds. During the soldering process, no force may be exerted on the relay terminals.
- Flux proof relays must not be washed, immersion cleaned or conformal coated as substances may enter the case and cause corrosion or seizure of mechanical parts.
- A minimum load of 10 mA / 5 V / 50 mW is recommended for gold plated contacts to ensure a reliable and stable connection.
- The datasheet and the component's specifications are subject to change without notice.

AZ696

DISCLAIMER

This product specification is to be used in conjunction with the application notes which can be downloaded from the regional ZETTLER relay websites. The specification provides an overview of the most significant part features. Any individual applications and operating conditions are not taken into consideration. It is recommended to test the product under application conditions. Responsibility for the application remains with the customer. Proper operation and service life cannot be guaranteed if the part is operated outside the specified limits.

ZETTLER GROUP

Building on a foundation of more than a century of expertise in German precision engineering, ZETTLER Group is a world-class enterprise, engaged in the design, manufacturing, sales and distribution of electronic components. Our industry leadership is based on a unique combination of engineering competence and global scale.

For more information on other ZETTLER Group companies, please visit [ZETTLER-group.com](https://www.zettler-group.com). For support on this product or other ZETTLER relays, please visit one of the group sites below.

SITES FOR ZETTLER RELAYS

NORTH AMERICA

American Zettler, Inc.
www.azettler.com
sales@azettler.com

EUROPE

Zettler Electronics, GmbH
www.zettlerelectronics.com
office@zettlerelectronics.com

Zettler Electronics, Poland
www.zettlerelectronics.pl
office@zettlerelectronics.pl

CHINA

Zettler Group, China
www.zettlercn.com
relay@zettlercn.com

ASIA PACIFIC

Zettler Electronics (HK) Ltd.
www.zettlerhk.com
sales@zettlerhk.com



ZETTLER